

CAN-Repeater

CRep Opto-.../DS24/RMD

CRep Opto-.../SS24/RMD

User Manual

EMS Sonnenhang 3
D-85304 IImmünster
Tel +49-8441/490260
THOMAS WÜNSCHE Fax +49-8441/81860

Documentation for CAN-Repeater CRep Opto-.../DS24/RMD
and CRep Opto-.../SS24/RMD.

Document version: V1.5
Documentation date: January 18th, 2007

No part of this document or the software described herein
may be reproduced in any form without prior written
agreement from EMS Dr. Thomas Wünsche.

For technical assistance please contact:

EMS Dr. Thomas Wünsche
Sonnenhang 3

D-85304 IImmünster

Tel. +49-8441- 490260

Fax +49-8441- 81860

Email: support@ems-wuensche.com

Our products are continuously improved. Due to this fact
specifications may be changed at any time and without
announcement.

WARNING: CRep Opto hardware and software may not
be used in applications where damage to
life, health or private property may result
from failures in or caused by these compo-
nents.

Contents

THIS PAGE INTENTIONALLY LEFT BLANK

1 Overview	1
1.1 Attributes	1
1.2 General Description	1
1.3 Ordering Information	2
2 Electrical Characteristics	3
2.1 Absolute Limiting Values	3
2.2 Nominal Values	3
3 Operating Instructions.	4
3.1 Layout and Pin Assignment	4
3.2 Block Diagram CRep Opto DS	6
3.3 Block Diagram CRep Opto SS	7
4 Dimensions.	9
5 Appendix A: Topology examples	10

1 Overview

1.1 Attributes

- Protocol transparent CAN repeater
- High throughput due to low latency
- ISO 11898 compatible bus interface with galvanic decoupling of CAN segments
- Connection complying to CiA DS102 standard
- Single or dual 12V-24V power supply
- Extended error suppression

1.2 General Description

The compact CAN repeater CRep Opto transmits and amplifies signals transparent to the CAN protocol. Each of the two galvanically separated CAN connections has the physical behaviour of a single bus node. CRep Opto permits a flexible design of the network topology. Star and tree structures can be implemented as well as long stub lines. By the possibility to use a network structure that fits the application best a reduction of installation costs can be achieved.

The maximum data rate in CAN networks, depending on signal propagation delays, can be increased, if CRep Opto is used to improve the network structure. An increase of the maximum node count in a CAN network can be reached by splitting the network into subnets that are connected by CRep Opto. Each subnet can apply the maximum number of CAN nodes permitted by the drivers output current. Where CAN signals have to be transmitted

over long distances, CRep Opto can be used for signal conditioning. Galvanic decoupling of the bus segments allows to connect subnets with differing ground potential by CRep Opto. The integrated shut down capability in case of errors reduces the impact on intact bus segments by defective segments for the most commonly occurring errors.

CRep Opto can be obtained in two different versions: CRep Opto DS24 has to be supplied from both network sides, CRep Opto SS24 is only supplied on CAN1.

1.3 Ordering Information

12-02-10x-20	CRep I-.../DS24/RMD CAN repeater for rail mount application, galvanic separation, double sided supply
12-02-20x-20	CRep I-.../SS24/RMD CAN repeater for rail mount application, galvanic separation, single sided supply
12-02-11x-20	CRep I-.../DS24/RMD-ETR CAN repeater for rail mount application, galvanic separation, double sided supply, extended temperature range
12-02-21x-20	CRep I-.../SS24/RMD-ETR CAN repeater for rail mount application, galvanic separation, single sided supply, extended temperature range

(... inhibit time)

2 Electrical Characteristics

2.1 Absolute Limiting Values

Any (also temporary) stress in excess of the limiting values may cause permanent damage on CRep Opto and connected devices.

Parameter	Min	Max	Unit
Storage temperature	-20	+80	°C
Operating temperature ¹	0	+60	°C
Power supply voltage	-100	+35	V
Voltage on signal lines	-30	+30	V

¹ Version ETR -20°C - +70°C

2.2 Nominal Values

All values, unless otherwise specified, refer to a supply voltage of 2.4V and an environmental temperature of 20°C.

Parameter	Min	Typ	Max	Unit
Current consumption ¹ (no load)	–	30	–	mA
Current consumption ¹ (250kBit/s, 100% load)	–	40	–	mA
Power supply voltage	10	24	30	V
Propagation delay	–	125	200	ns

¹ with 24V supply voltage

3 Operating Instructions

3.1 Layout and Pin Assignment

CRep Opto devices include 2 CAN segments fed to a male and a female plug of type D-Sub 9. The plugs carry the CAN signals and the supply voltage.

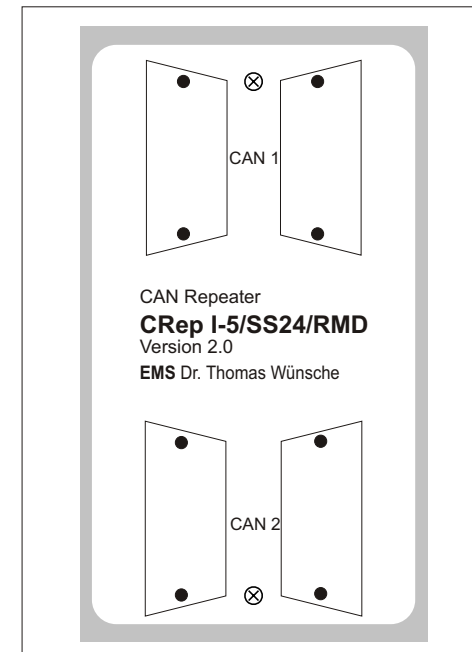

The following table shows the pin assignment of the D-Sub 9 plugs (male and female plug are connected internally):

Pin	Name	Function
2	CAN_L	CAN_Low bus line
3	GND	Ground
7	CAN_H	CAN_High bus line
9	V+CAN	Power supply 24V

Please notice that CRep Opto SS can only be supplied over CAN1.

3.2 Block Diagram CRep Opto DS

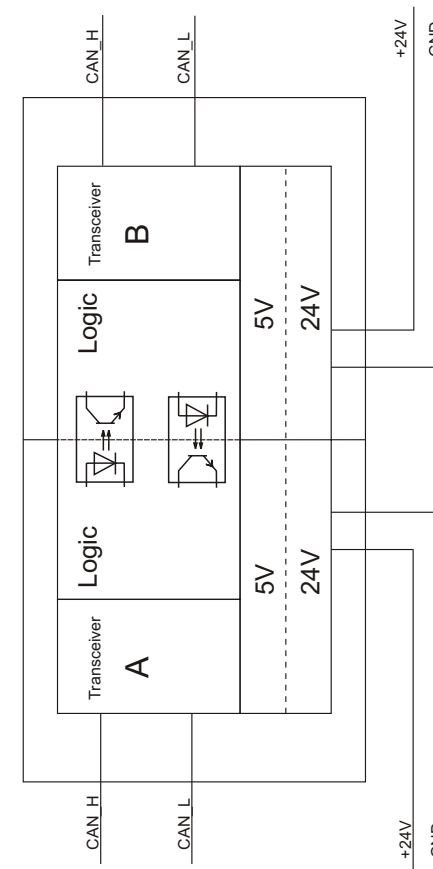

3.3 Block Diagram CRep Opto SS

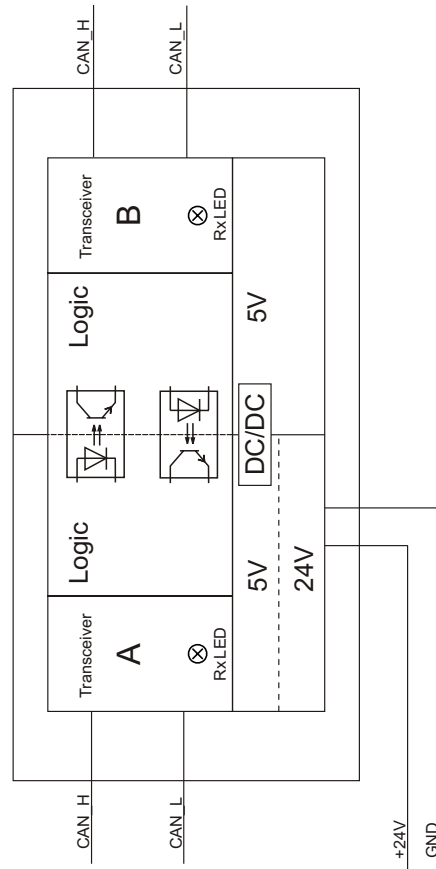

4 Dimensions

All values in [mm].

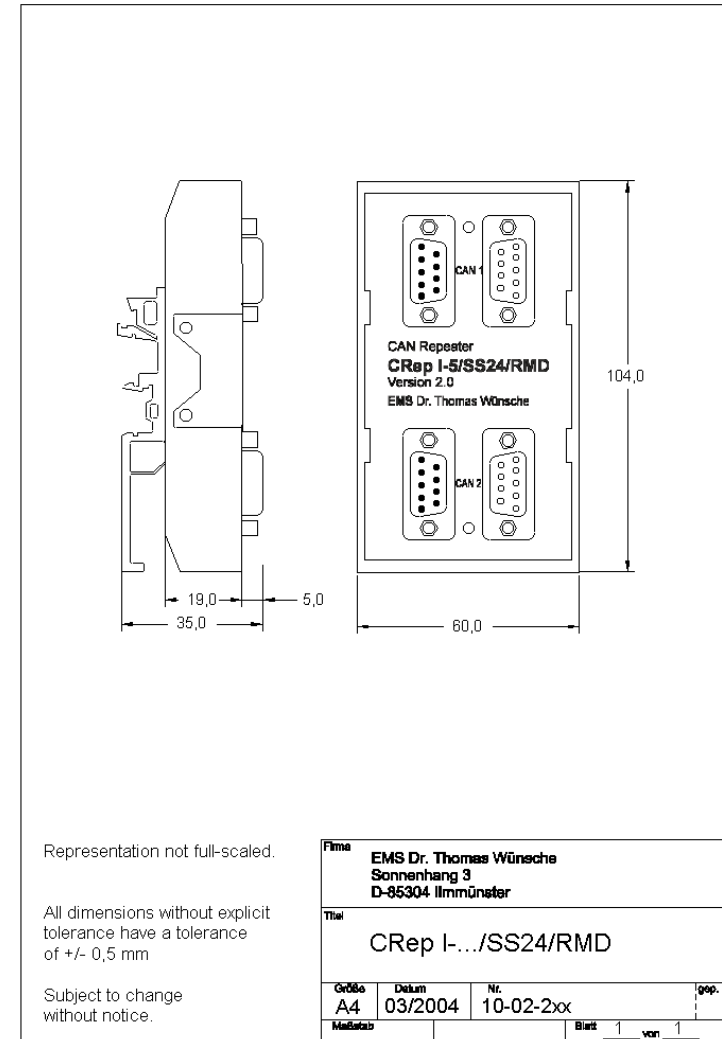

5 Appendix A: Topology examples

CAN busses should always be terminated on both ends, typically using a 120Ohm termination resistor between CAN-High and CAN-Low signal lines.

Legend



Line topology with repeaters

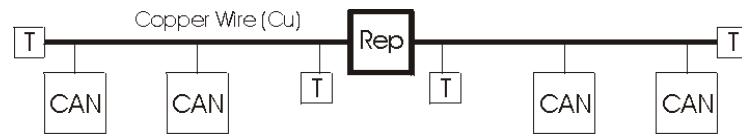

Tree topology with repeaters

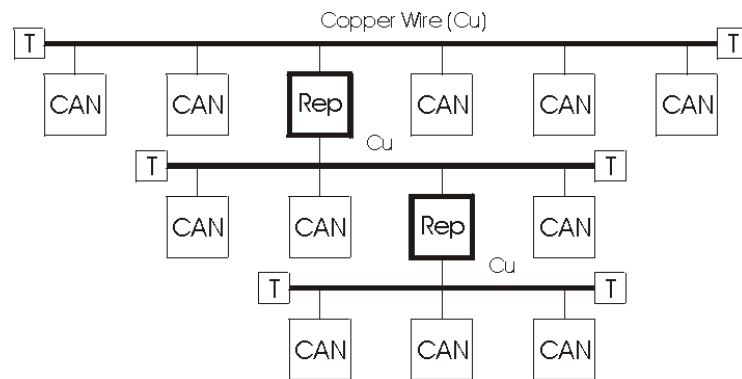

Star topology with repeaters

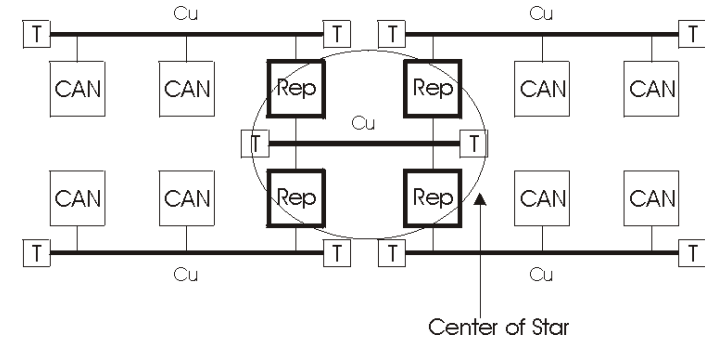

THIS PAGE INTENTIONALLY LEFT BLANK